



**CLASS 125 / 200 W.O.G.**

**FLANGE TYPE**

**HYDROSTATICS PRESSURE: 125 PSI (NON-SHOCK)**

**SHELL TEST: 300 PSI**

**SEAT TEST: 200 PSI**

## SWING CHECK VALVE

SWING CHECK VALVE		
PARTS	MATERIALS	ASTM SPECIFICATIONS
1. Body	Cast Iron	A126 CL. B
2. Cover	Cast Iron	A126 CL. B
3. Hinge Pin	Stainless Steel	A276 TYPE403
4. Disc	Cast Iron	A126 CL. B
5. Seat Ring	Bronze	B62
6. Body Seat Ring	Bronze	B62
7. Arm	Non-Asbestos	
8. Gasket	Non-Asbestos	
9. Cover B&N	Carbon Steel	
10. Gland B&N	Carbon Steel	

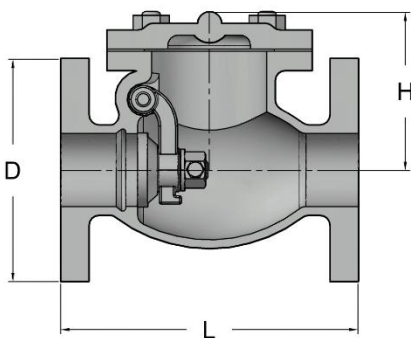
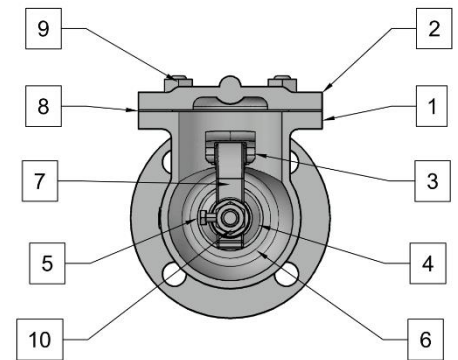

DIMENSIONS (mm)										
Size	1½" (40)	2" (50)	2½" (65)	3" (80)	4" (100)	5" (125)	6" (150)	8" (200)	10" (250)	12" (300)
<b>L</b>	203	203	216	241	292	330	356	496	622	699
<b>H</b>	108	108	124	137	159	183	203	246	283	333
<b>D</b>	127	152	178	190	229	254	279	343	406	483