

DAYO VALVES

DAYO VALVES COMPANY LTD. -JAPAN



CLASS 125 / 200 W.O.G.

FLANGE TYPE

NON-RISING STEM (NRS)

HYDROSTATICS PRESSURE: 125 PSI (NON-SHOCK)

SHELL TEST: 300 PSI

SEAT TEST: 200 PSI

NON-RISING STEM NRS GATE VALVES

NON-RISING STEM NRS GATE VALVES		
PARTS	MATERIALS	ASTM SPECIFICATIONS
1. Body	Cast Iron	A126 CL. B
2. Bonnet	Cast Iron	A126 CL. B
3. Stem	Brass	A276 TYPE403
4. Disc	Cast Iron	B62
5. Seat Ring	Bronze	B62
6. Gland	Ductile Iron	
7. Packing	Non-Asbestos	
8. Gasket	Non-Asbestos	
9. Gland B&N	Carbon Steel	
10. Yoke Sleeve	Bronze	
11. Handwheel	Ductile Iron	

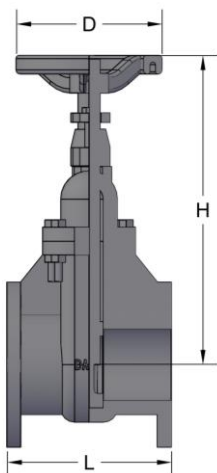
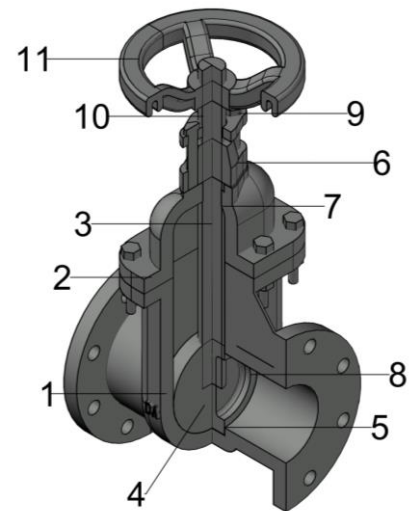

DIMENSIONS (mm)											
Size	1½" (40)	2" (50)	2½" (65)	3" (80)	4" (100)	5" (125)	6" (150)	8" (200)	10" (250)	12" (300)	14" (350)
L	165	178	190	200	228	250	267	292	330	354	383
H	220	252	270	290	365	420	455	575	686	782	910
D	127	152	178	190	229	254	279	343	406	483	533



89 Anahaw St., Veterans Village, Project 7, Quezon City 1105

Tel: (02) 8285-7080

<https://pinoleakpes.wixsite.com/pinoleakpes>