



**CLASS 125 / 200 W.O.G.**

**FLANGE TYPE**

**RISING STEM (OS&Y)**

**HYDROSTATICS PRESSURE: 125 PSI (NON-SHOCK)**

**SHELL TEST: 300 PSI**

**SEAT TEST: 200 PSI**

## RISING STEM (OS&Y) GATE VALVES

RISING STEM (OS&Y) GATE VALVES		
PARTS	MATERIALS	ASTM SPECIFICATIONS
1. Body	Cast Iron	A126 CL. B
2. Bonnet	Cast Iron	A126 CL. B
3. Stem	Brass	A276 TYPE403
4. Disc	Cast Iron	B62
5. Seat Ring	Bronze	B62
6. Gland	Ductile Iron	
7. Packing	Non-Asbestos	
8. Gasket	Non-Asbestos	
9. Gland B&N	Carbon Steel	
10. Bonnet B&N	Carbon Steel	
11. Yoke Sleeve	Bronze	
12. Handwheel	Ductile Iron	

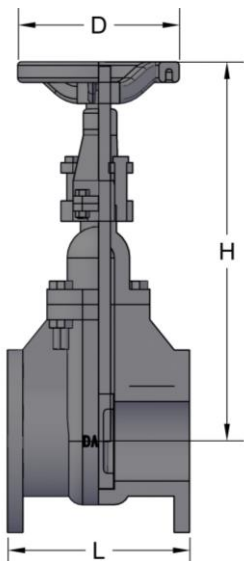
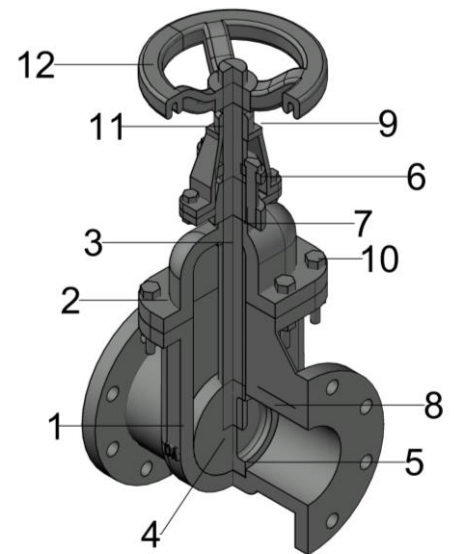

DIMENSIONS (mm)											
Size	1½" (40)	2" (50)	2½" (65)	3" (80)	4" (100)	5" (125)	6" (150)	8" (200)	10" (250)	12" (300)	14" (350)
L	165	178	190	200	228	250	267	292	330	354	383
H	240	267	280	300	405	460	560	705	880	1100	1270
D	127	152	178	190	229	254	279	343	406	483	533