



MECH FLOW SUPPLIES



Malleable Iron Pipe Fittings



Ductile Iron Grooved Fittings and Couplings



Valves



Cast Bronze Fittings



Electrical Power Fittings



Malleable Iron Pipe Clamps



Ductile Iron Pipe Fittings
Cast Iron Pipe Fittings



Pipe Nipples



JINAN MEIDE CASTING CO., LTD.

Address: Meide Science & Technology Park,
Industrial Park Pingyin, Jinan, China 250400

Phone: (86)531 87879384 87885036 87885067

Fax: (86)531 87879387

Email: info@meide-casting.com

Http://www.meide-casting.com



UPDATED 08/2018

Malleable Iron Pipe Fittings

American Standard

To Provide **Safe & Reliable** Products and **Smart & Complete** Solutions for Clients in Fluid Conveying Industry Across the Globe.



More than 50 years of Foundry Experience

Company Profile

Jinan Meide Casting Co. Ltd. was established in 1961. In the past decades, Jinan Meide has seized each opportunity to consolidate its strength, and has finally developed into what it is today, a large-scale enterprise group with advanced technology, equipment and strong comprehensive strength, known for its complete range of products, large producing capacity, high quality and strong R&D strength. The company owns altogether one main factory, three branch factories, two independent accounting steel pipe companies, and a science & technology park.

The company is the well-known manufacturer in the fitting industry with the most complete range of products, supplying malleable iron fittings, grooved fittings, grooved couplings, valves, cast iron fittings, ductile iron fittings, steel pipe nipples and couplings, stainless steel nipples, brass pipe nipples, cast bronze fittings, steel pipes, pipe hangers and supports, electric fittings, etc.

Over 50 years, Jinan Meide has been a trusted name in piping solutions by offering high-quality products, service and support to the PVF industry continuously. We provide expertise and product solutions for a wide range of applications, plumbing, mechanical, industrial, air-conditioning and refrigeration, mining, oil, gas, fire protection, equipment and power system. Many of the company's application technology are advanced in the world, with more than 20 patents registered each year, and the company has presided over and participated in the drafting of many important national standards of the industry.

We organize the whole production process in accordance with ISO 9001 and ISO 14001. It has also the most complete certificates in the PVF industry, including UL/FM/NSF of US, CRN/cUL of Canada, DVGW/TUV/CE/VdS of Germany, BSI/LPCB of UK, SII of Israel, JIS of Japan, ABNT of Brazil, GOST-R of Russia, CNBOP of Poland, KS of South Korea, TSE of Turkey, PSB of Singapore, SIRIM of Malaysia, SABS of South Africa etc. The products are well distributed in more than 130 countries and regions.

As an industry leader and key high-tech enterprise of the national torch plan, the company attaches great importance to environmental protection, energy-saving and emission-reduction. US-EEC recognizes MECH brand malleable iron pipe fittings as "the product to promote for the technology exchange of environmental protection". Protecting the environment is the duty of the company.

Customer satisfaction has always been the company's top objective, and we constantly stick to the principle: to provide customers with a value-added solution rather than simply delivering products.

Company History

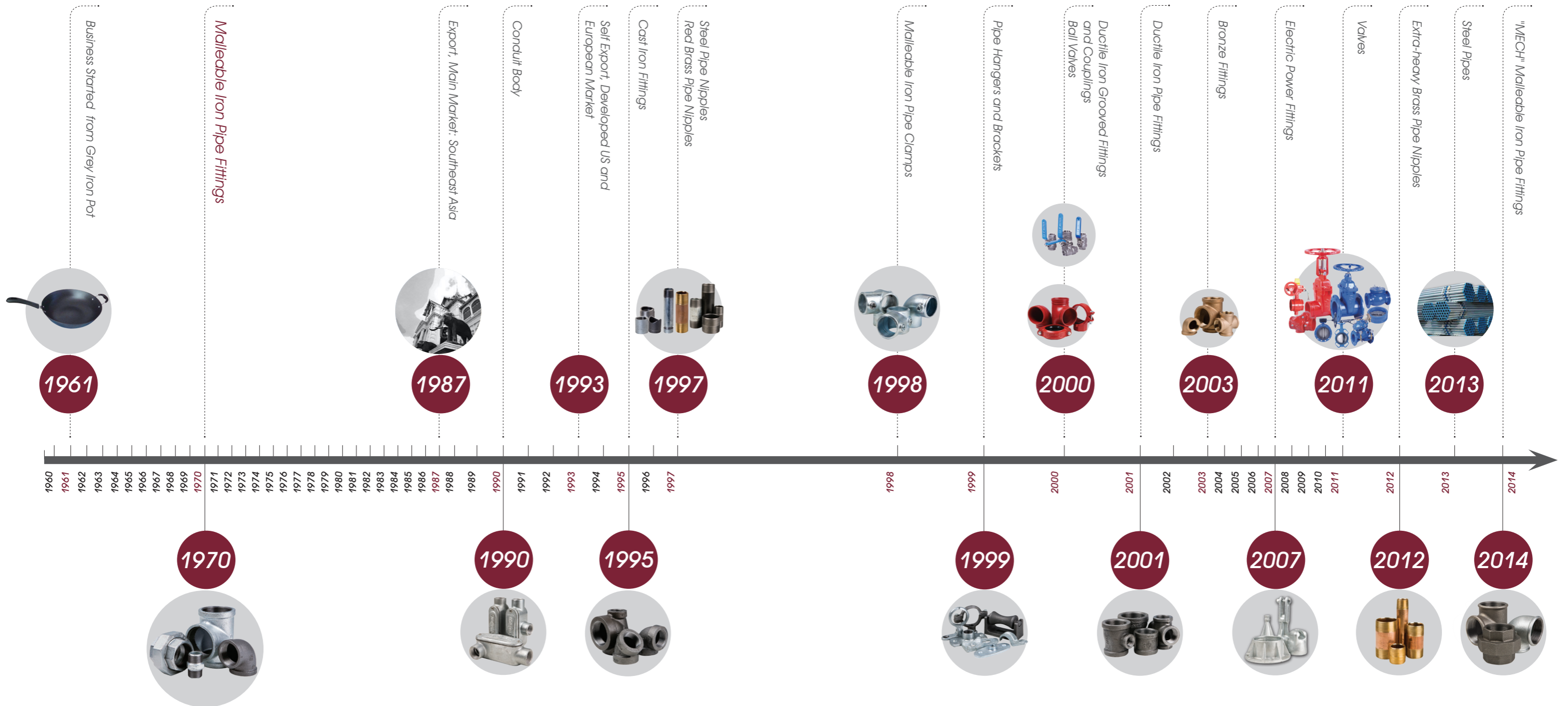
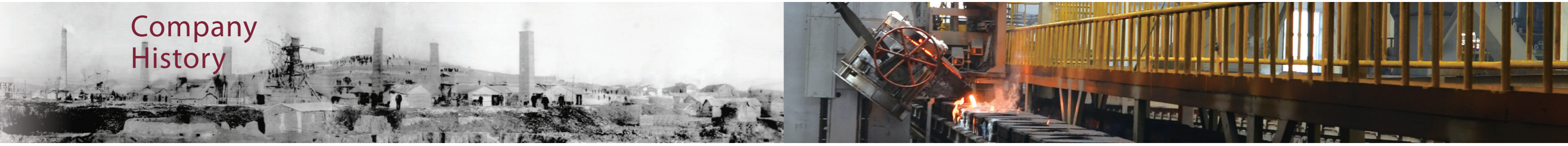

State of the Art Equipment

High precision equipment is quality assurance. Jinan Meide's 8 factories are all equipped with the most advanced facilities and equipment in the industry. The main production facilities include Sinto automatic molding line, Tokyu automatic molding line, Chinese 416 automatic vertical molding line, automatic molding sand mixers, cupola furnaces, electric furnaces, water-cooled longevous cupola furnaces, CNC vertical machining centers, CNC machines, NC vertical lathes, radial drills, Jinan Meide proprietary automatic machines, hot-dipped galvanization line, automatic box sealing line, stereoscopic warehouse and so on.



Pattern



Core Making



Sand Mulling



Tokyu AMF-111055



DISA



Sinto FCMX



Melting



Pouring



Annealing



End Grinding Line



Warehouse



Threading, Air Pressure Test, and Anti-rust Treatment

Reliable Quality Assurance

Jinan Meide is honored as the National enterprise technical center and is capable and qualified to conduct full series of tests and inspections including chemical checking, etc.

Inspection facilities include: spectrometer, carbon sulfur analyzer, metallurgical microscope, tensile strength testing equipment, pressure testing equipment, adhesive force testing equipment, CMM, hardness tester, etc.

From incoming inspection to finished product, quality is checked and monitored in the whole process. Each step of the manufacturing process is carefully documented, regularly reviewed for revision control and updating standard. Quality procedures are constantly monitored and updated to assure that only the highest and most consistent quality products are supplied to our valued customers.



Metallurgical Microscope



Spectrometer

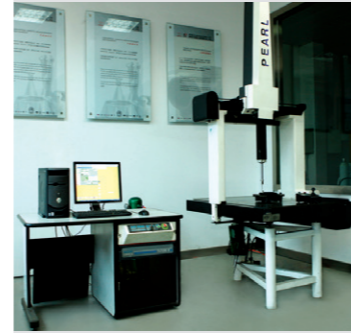

CMM

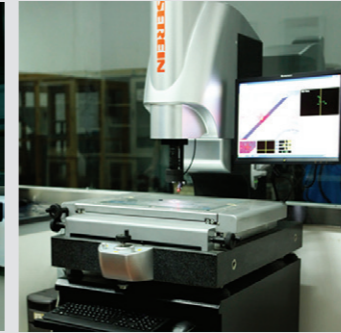

Projector

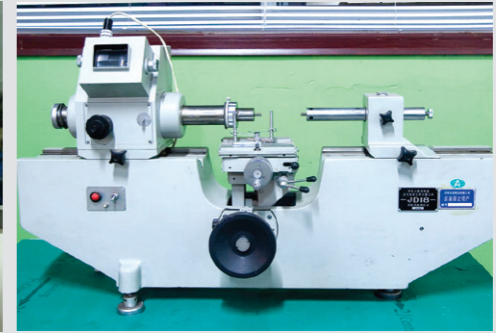

The Length of The Test Instrument

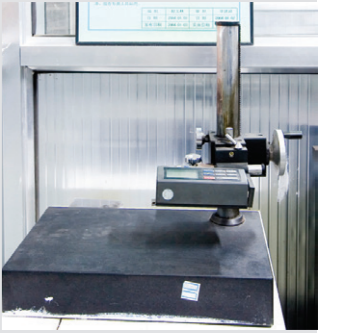

Roughness Tester



Carbon Sulfur Analyzer



Tensile Strength Testing Equipment



Sand Testing Instrument

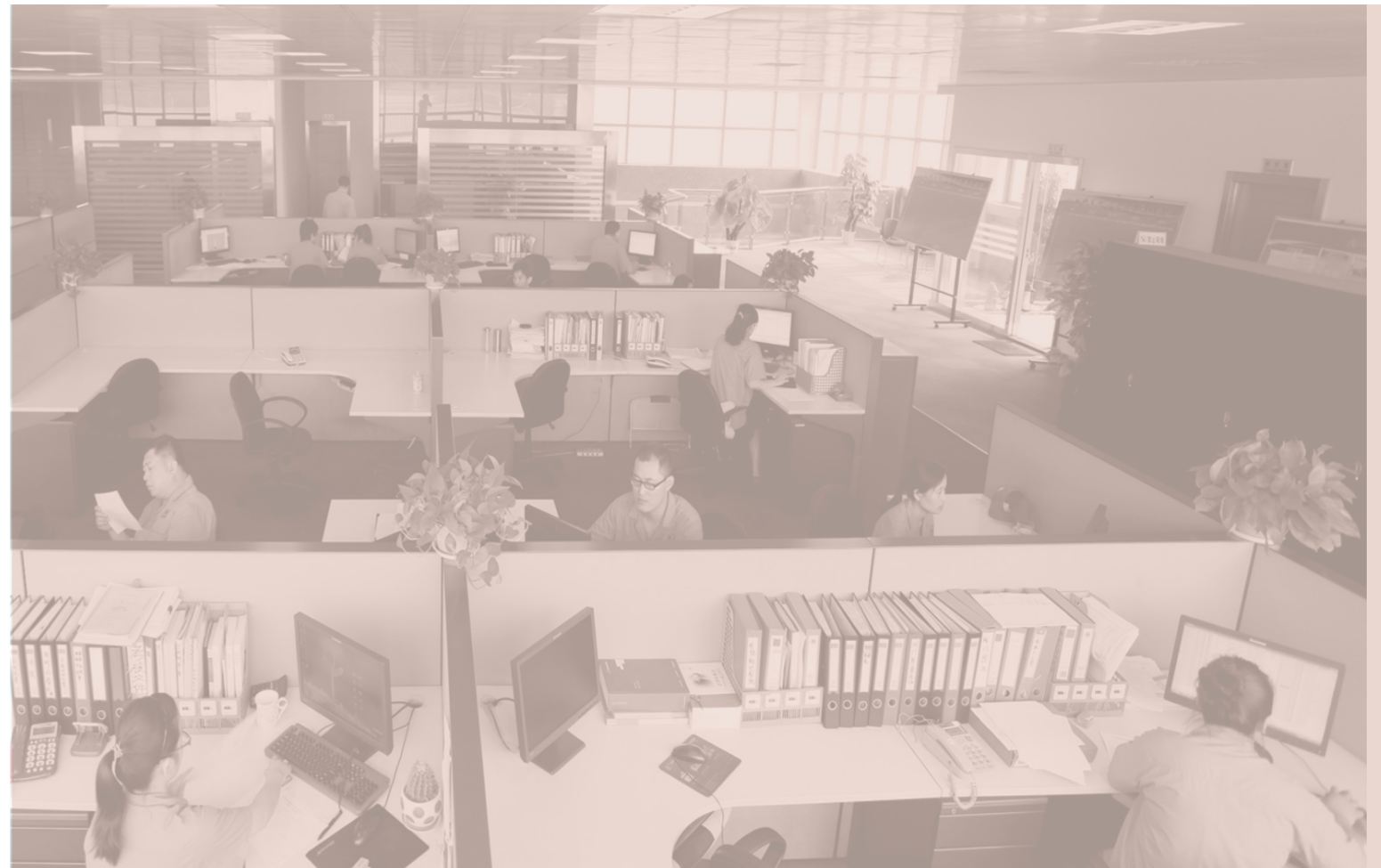

Certificates

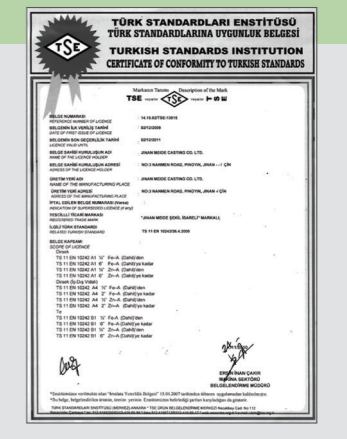
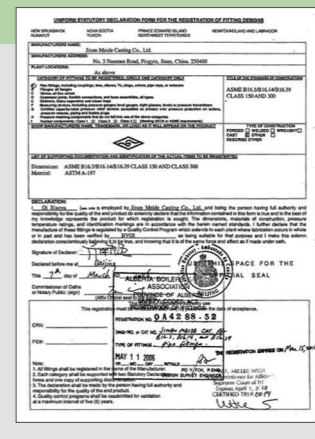
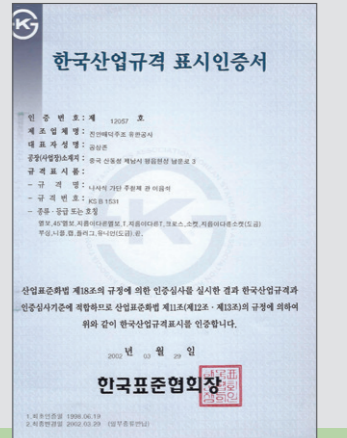

Malleable Iron Pipe Fittings

American Standard Class 150

Material: ASTM A197/A197M
 Dimensions: ASME B16.3, B16.14
 Union Dimensions: B16.39
 Threads: ASME B1.20.1
 Size Available: 1/8" - 8"



90

90° Elbow

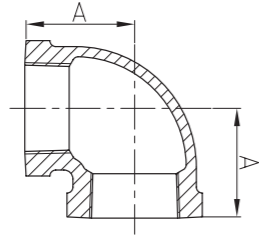

Size	Inch	1/8	1/4	3/8	1/2	3/4	1	1 1/4	1 1/2
	mm	6	8	10	15	20	25	32	40
Dim. (mm)	A	17.5	20.6	24.1	28.5	33.3	38.1	44.5	49.3
	B	17.5	20.6	24.1	28.5	33.3	38.1	44.5	49.3
Size	Inch	2	2 1/2	3	4	5	6	8	
	mm	50	65	80	100	125	150	200	
Dim. (mm)	A	57.2	68.6	78.2	96.3	114.3	130.3	162	
	B	57.2	68.6	78.2	96.3	114.3	130.3	162	

90R

90° Reducing Elbow

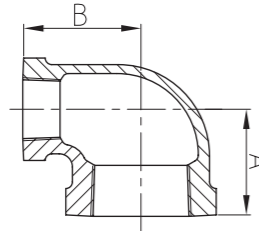

Size	Inch	4X1 1/4	4X1 1/2	4X2	4X2 1/2	4X3	3/8X1/8
	mm	100X32	100X40	100X50	100X65	100X80	10X6
Dim. (mm)	A	60	62	69	78	83.8	20.5
	B	85	85	87	90	91.4	21.6
Size	Inch	3/8X1/4	6X4	1/2X1/4	1/2X3/8	3/4X1/4	3/4X3/8
	mm	10X8	150X100	15X8	15X10	20X8	20X10
Dim. (mm)	A	22.4	102	24.6	26.4	26.7	28.5
	B	22.9	125	24.9	26.2	27.4	28.7

90R

90° Reducing Elbow

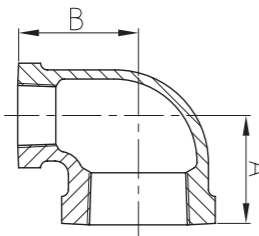

Size	Inch	3/4X1/2	1X1/4	1X3/8	1X1/2	1X3/4
	mm	20X15	25X8	25X10	25X15	25X20
Dim. (mm)	A	30.5	27	30	32	34.8
	B	31	31	32.3	35.5	36.8
Size	Inch	1 1/4X3/8	1 1/4X1/2	1 1/4X3/4	1 1/4X1	1 1/2X1/2
	mm	32X10	32X15	32X20	32X25	40X15
Dim. (mm)	A	32	34	36.8	40.1	35
	B	36.5	38.9	41.2	42.4	41.5

90R

90° Reducing Elbow

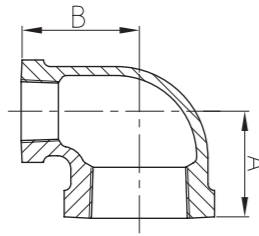

Size	Inch	1 1/2X3/4	1 1/2X1	1 1/2X1 1/4	2X1/2	2X3/4
	mm	40X20	40X25	40X32	50X15	50X20
Dim. (mm)	A	38.6	41.9	46.2	37.5	40.6
	B	44.5	45.7	47.8	47.5	50.0
Size	Inch	2X1	2X1 1/4	2X1 1/2	2 1/2X3/4	2 1/2X1
	mm	50X25	50X32	50X40	65X20	65X25
Dim. (mm)	A	43.9	48.3	51.3	42	46
	B	51.3	53.3	54.9	57	58.7

90R

90° Reducing Elbow

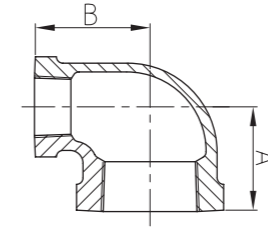

Size	Inch	2 1/2X1 1/4	2 1/2X1 1/2	2 1/2X2	3X3/4	3X1
	mm	65X32	65X40	65X50	80X20	80X25
Dim. (mm)	A	50.5	54.9	60.7	45	50
	B	60	63.8	66.0	65	67.5
Size	Inch	3X1 1/4	3X1 1/2	3X2	3X2 1/2	1/4X1/8
	mm	80X32	80X40	80X50	80X65	8X6
Dim. (mm)	A	55	58	64	71.9	18.8
	B	70	72	73.4	75.9	19.3

90U

180° Return Elbow

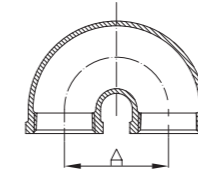

Size	Inch	1/2	2			
	mm	15	50			
Dim. (mm)	A	38.1	101.6			
	B					
Size	Inch					
	mm					
Dim. (mm)	A					
	B					

92

90° Street Elbow

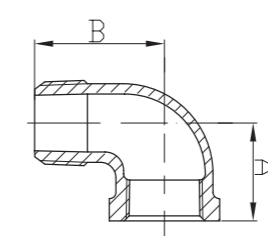

Size	Inch	1/8	1/4	3/8	1/2	3/4	1	1 1/4
	mm	6	8	10	15	20	25	32
Dim. (mm)	A	17.5	20.6	24.1	28.5	33.3	38.1	44.5
	B	25.4	30.2	36.6	41.2	48.0	54.4	62.2
Size	Inch	1 1/2	2	2 1/2	3	4	6	
	mm	40	50	65	80	100	150	
Dim. (mm)	A	49.3	57.2	68.6	78.2	96.3	130.3	
	B	68.3	82.8	98.0	114.6	144.5	204.0	

92R

90° Reducing Street Elbow

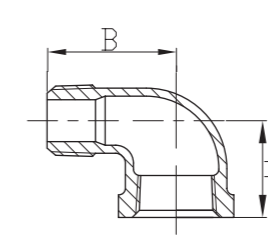

Size	Inch	3/4X1/2	1X3/4	1 1/4X1	1 1/2X1 1/4
	mm	20X15	25X20	32X25	40X32
Dim. (mm)	A	30	35	40	
	B	40	46	56	
Size	Inch				
	mm				
Dim. (mm)	A				
	B				

96A Union Elbow

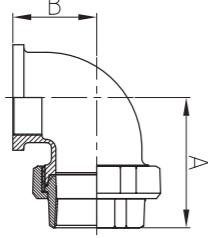
Size	Inch	1/2	3/4	1	1 1/4	1 1/2	2
	mm	15	20	25	32	40	50
Dim. (mm)	A	57	59	72	82	88	99
	B	27	29	34	43	47	56
Size	Inch						
	mm						
Dim. (mm)	A						
	B						

120 45° Elbow

Size	Inch	1/8	1/4	3/8	1/2	3/4	1	1 1/4	1 1/2
	mm	6	8	10	15	20	25	32	40
Dim. (mm)	A	16	18.5	20.3	22.4	24.9	28.5	32.8	36.3
	B								
Size	Inch	2	2 1/2	3	4	5	6	8	
	mm	50	65	80	100	125	150	200	
Dim. (mm)	A	42.7	49.5	55.1	66.3	77.5	87.9	106.7	
	B								

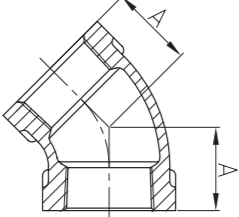
121 45° Street Elbow

Size	Inch	1/8	1/4	3/8	1/2	3/4	1
	mm	6	8	10	15	20	25
Dim. (mm)	A	16	18.5	20.3	22.4	24.9	28.5
	B	21	23.9	26.2	29.2	32.8	37.3
Size	Inch	1 1/4	1 1/2	2	2 1/2	3	4
	mm	32	40	50	65	80	100
Dim. (mm)	A	32.8	36.3	42.7	49.5	55.1	66.3
	B	43.4	47.8	56.4	65.3	76.2	94.0

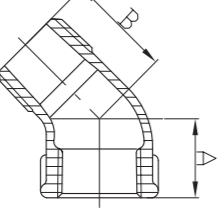
130 Tee

Size	Inch	1/8	1/4	3/8	1/2	3/4	1	1 1/4	1 1/2
	mm	6	8	10	15	20	25	32	40
Dim. (mm)	A	17.5	20.6	24.1	28.5	33.3	38.1	44.5	49.3
	B								
Size	Inch	2	2 1/2	3	4	5	6	8	
	mm	50	65	80	100	125	150	200	
Dim. (mm)	A	57.2	68.6	78.2	96.3	114.3	130.3	162	
	B								

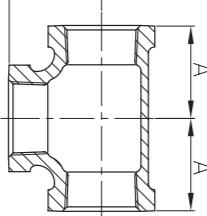
130R Bull Head Tee

Size	Inch	1/2X1/2X3/4	1/2X1/2X1	3/4X3/4X1	3/4X3/4X1 1/4
	mm	15X15X20	15X15X25	20X20X25	20X20X32
Dim. (mm)	A	31	34.6	36.8	41.2
	B	30.5	32.0	34.8	36.8
Size	Inch	1X1X1 1/4	1X1X1 1/2	1X1X2	1X1X2 1/2
	mm	25X25X32	25X25X40	25X25X50	25X25X65
Dim. (mm)	A	42.4	45.7	51.3	60
	B	40.1	41.9	48.9	48

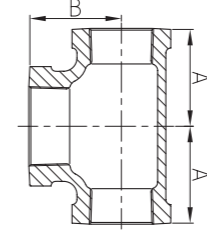
130R Bull Head Tee

Size	Inch	1 1/4X1 1/4X1 1/2	1 1/4X1 1/4X2	1 1/2X1 1/2X2	1 1/2X1 1/2X2 1/2
	mm	32X32X40	32X32X50	40X40X50	40X40X65
Dim. (mm)	A	47.8	53.3	54.9	62
	B	46.2	48.3	51.3	55
Size	Inch	2X2X2 1/2	2 1/2X2 1/2X3	2 1/2X2 1/2X4	
	mm	50X50X65	65X65X80	65X65X100	
Dim. (mm)	A	66	76	90	
	B	60.7	71.9	78	

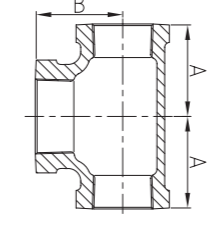
130R Reducing Tee

Size	Inch	4X1/2	4X3/4	4X1	4X1 1/4	4X1 1/2	4X2
	mm	100X15	100X20	100X25	100X32	100X40	100X50
Dim. (mm)	A	50	53	56	60	63.8	69.6
	B	79	79	82	84	84.3	86.6
Size	Inch	4X2 1/2	4X3	3/8X1 1/4	6X4	6X2	6X3
	mm	100X65	100X80	10X8	150X100	150X50	150X80
Dim. (mm)	A	77.5	83.8	22.4	104.9	78.2	92.5
	B	89.2	91.4	22.9	125.5	115.8	120.7

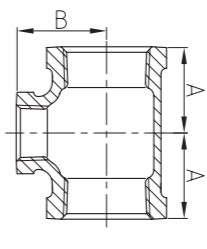
130R Reducing Tee

Size	Inch	1/2X1/8	1/2X1/4	1/2X3/8	3/4X1/4	3/4X3/8
	mm	15X6	15X8	15X10	20X8	20X10
Dim. (mm)	A	22	24.6	26.4	26.7	28.5
	B	23	24.9	26.2	27.4	28.7
Size	Inch	3/4X1/2	1X1/4	1X3/8	1X1/2	1X3/4
	mm	20X15	25X8	25X10	25X15	25X20
Dim. (mm)	A	30.5	28.2	30	32	34.8
	B	31	31	32.3	35.5	36.8

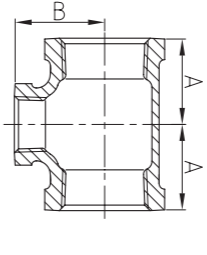
130R

Reducing Tee

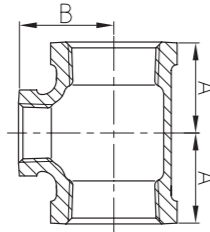

Size	Inch	11/4X3/8	11/4X1/2	11/4X3/4	11/4X1	11/2X3/8
	mm	32X10	32X15	32X20	32X25	40X10
Dim. (mm)	A	32	34	36.8	40.1	34
	B	36.6	38.9	41.2	42.4	39
Size	Inch	11/2X1/2	11/2X3/4	11/2X1	11/2X11/4	2X3/8
	mm	40X15	40X20	40X25	40X32	50X10
Dim. (mm)	A	35.8	38.6	41.9	46.2	36
	B	42.2	44.5	45.7	47.8	46

130R

Reducing Tee

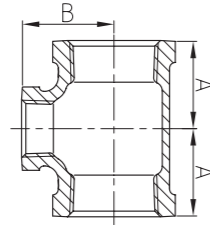

Size	Inch	2X1/2	2X3/4	2X1	2X11/4	2X11/2
	mm	50X15	50X20	50X25	50X32	50X40
Dim. (mm)	A	37.9	40.6	43.9	48.3	51.3
	B	47.8	50	51.3	53.3	54.9
Size	Inch	21/2X1/2	21/2X3/4	21/2X1	21/2X11/4	21/2X11/2
	mm	65X15	65X20	65X25	65X32	65X40
Dim. (mm)	A	41	44.2	47.5	51.8	54.9
	B	57	58.9	60.2	62.2	63.8

130R

Reducing Tee

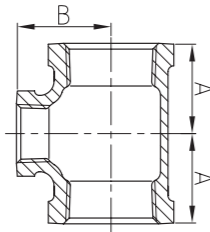

Size	Inch	21/2X2	3X1/2	3X3/4	3X1	3X11/4
	mm	65X50	80X15	80X20	80X25	80X32
Dim. (mm)	A	60.7	42	47.5	50.8	55.1
	B	66.0	64	66.3	67.6	69.6
Size	Inch	3X11/2	3X2	3X21/2	1/4X1/8	
	mm	80X40	80X50	80X65	8X6	
Dim. (mm)	A	58.2	64.0	71.9	18.8	
	B	71.1	73.4	76	19.3	

130R

Reducing Tee

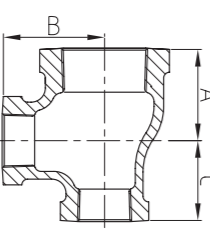

Size	Inch	3/4X1/2X1/2	1X1/2X1/2	1X3/4X3/4	11/4X1/2X1/2
	mm	20X15X15	25X15X15	25X20X20	32X15X15
Dim. (mm)	A	30.5	32	34.8	34
	B	31	35.5	36.8	38
Dim. (mm)	C	28.5	28.5	33.3	27
	Size	Inch	11/4X3/4X3/4	11/4X1X1	11/2X3/4X3/4
Dim. (mm)	mm	32X20X20	32X25X25	40X20X20	40X25X25
	A	36.8	40.1	38	41.9
Dim. (mm)	B	41.2	42.4	43	45.7
	C	33.3	38.1	32	38.1

130R

Reducing Tee

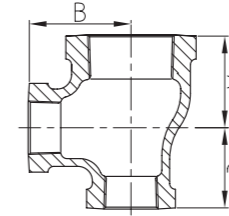

Size	Inch	11/2X11/4X11/4	2X1X1	2X11/4X11/4	2X11/2X11/2
	mm	40X32X32	50X25X25	50X32X32	50X40X40
Dim. (mm)	A	46.2	44	48.3	51.3
	B	47.8	51	53.3	54.9
Dim. (mm)	C	44.5	38	44.5	49.3
	Size	Inch	21/2X2X2	3X2X2	
Dim. (mm)	mm	65X50X50	80X50X50		
	A	60.7	64		
Dim. (mm)	B	66	73.4		
	C	57.2	57.2		

130R

Reducing Tee

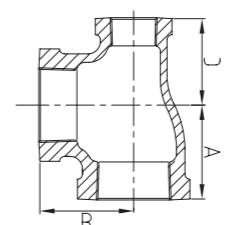

Size	Inch	3/4X1/2X3/4	1X1/4X1	1X1/2X1	1X3/4X1	11/4X1/2X11/4
	mm	20X15X20	25X8X25	25X15X25	25X20X25	32X15X32
Dim. (mm)	A	33.3	37	38.1	38.1	44.5
	B	33.3	37	38.1	38.1	44.5
Dim. (mm)	C	31	30	35.5	36.8	38.9
	Size	Inch	11/4X3/4X11/4	11/4X1X11/4	11/2X1/2X11/2	11/2X3/4X11/2
Dim. (mm)	mm	32X20X32	32X25X32	40X15X40	40X20X40	40X25X40
	A	44.5	44.5	49.3	49.3	49.3
Dim. (mm)	B	44.5	44.5	49.3	49.3	49.3
	C	41.2	42.4	42.2	44.5	45.7

130R

Reducing Tee

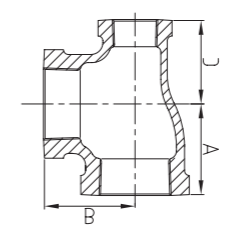

Size	Inch	11/2X11/4X11/2	2X1/2X2	2X3/4X2	2X1X2
	mm	40X32X40	50X15X50	50X20X50	50X25X50
Dim. (mm)	A	49.3	57.2	57.2	57.2
	B	49.3	57.2	57.2	57.2
Dim. (mm)	C	47.8	47.8	50	51.3
	Size	Inch	2X11/4X2	2X11/2X2	21/2X11/2X21/2
Dim. (mm)	mm	50X32X50	50X40X50	65X40X65	65X50X65
	A	57.2	57.2	68.6	68.6
Dim. (mm)	B	57.2	57.2	68.6	68.6
	C	53.3	54.8	63.8	66

130R

Reducing Tee

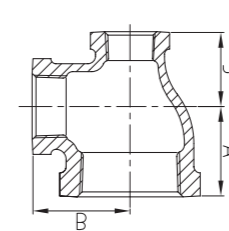

Size	Inch	4X3X2	3/4X1/2X1	1X1/2X3/4	11/4X1/2X3/4	11/4X1/2X11/4
	mm	100X80X50	20X15X25	25X15X20	32X15X20	32X15X25
Dim. (mm)	A	67	38	34.8	35	40.1
	B	83.5	34	36.8	38	42.4
Dim. (mm)	C	60	33	31	29	34.5
	Size	Inch	11/4X3/4X1/2	11/4X3/4X1	11/4X1X1/2	11/4X1X3/4
Dim. (mm)	mm	32X20X15	32X20X25	32X25X15	32X25X20	40X15X25
	A	40	40.1	34.0	36.8	44
Dim. (mm)	B	42.5	42.4	38.9	41.2	46
	C	37	36.8	32	34.8	34

130R

Reducing Tee

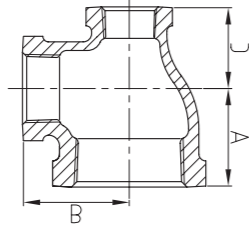

Size	Inch	1 1/2X3/4X1	1 1/2X3/4X1 1/4	1 1/2X1X1/2	1 1/2X3/4X1 1/4	1 1/2X1 1/4X1/2
	mm	40X20X25	40X20X32	40X25X15	40X25X32	40X32X15
Dim. (mm)	A	44	46	37	45	35.8
	B	46	48	41	47	42.2
	C	35	41	32	41.5	34.0
Size	Inch	1 1/2X1 1/4X3/4	1 1/2X1 1/4X1	1 1/2X1 1/4X2	2X1X1 1/2	2X1 1/4X1
	mm	40X32X20	40X32X25	40X32X50	50X25X40	50X32X25
Dim. (mm)	A	38.6	41.9	55	51.3	40
	B	44.5	45.7	51.5	54.9	51
	C	36.3	40.1	53.5	45.7	44

130R

Reducing Tee

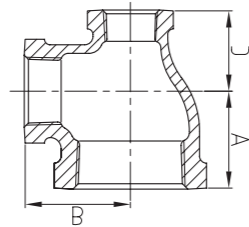

Size	Inch	2X1 1/4X1 1/2	2X1 1/2X1/2	2X1 1/2X3/4	2X1 1/2X1	2X1 1/2X1 1/4
	mm	50X32X40	50X40X15	50X40X20	50X40X25	50X40X32
Dim. (mm)	A	51.3	38	39.5	43.9	48.3
	B	54.9	48	49	51.3	53.3
	C	47.8	36	37.5	41.9	46.2
Size	Inch	2 1/2X2X1/2	2 1/2X2X1	2 1/2X2X1 1/4	3X2 1/2X2	
	mm	65X50X15	65X50X25	65X50X32	80X65X50	
Dim. (mm)	A	57	53	57	64.0	
	B	64	60	64	73.4	
	C	52	53	52	60.7	

134

Service Tee

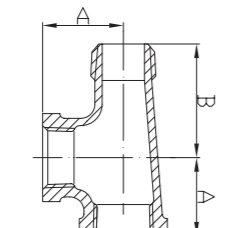

Size	Inch	1/4	1/2	3/4	1	1 1/4	1 1/2
	mm	8	15	20	25	32	40
Dim. (mm)	A	20.6	28.5	33.3	38.1	44.5	49.3
	B	30.2	41.2	48.0	54.4	62.2	68.3
Size	Inch	2	3				
	mm	50	80				
Dim. (mm)	A	57.2	78.2				
	B	82.8	114.6				

165

45° Lateral Y Branch

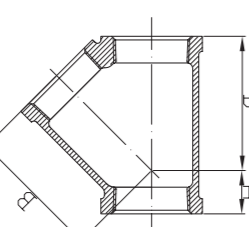

Size	Inch	3/8	1/2	3/4	1	1 1/4	1 1/2
	mm	10	15	20	25	32	40
Dim. (mm)	A	12.7	15.5	18.3	21.6	25.9	27.9
	B	36.3	43.4	52.1	61.7	74.2	83.3
Size	Inch	2	2 1/2	3	4		
	mm	50	65	80	100		
Dim. (mm)	A	37.5	38.6	43.4	51.1		
	B	99.8	120.1	141	177		

180

Cross

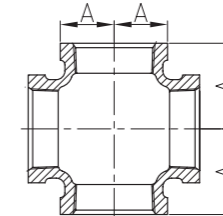

Size	Inch	1/8	1/4	3/8	1/2	3/4	1
	mm	6	8	10	15	20	25
Dim. (mm)	A	17.5	20.6	24.1	28.5	33.3	38.1
	B						
Size	Inch	1 1/4	1 1/2	2	2 1/2	3	4
	mm	32	40	50	65	80	100
Dim. (mm)	A	44.5	49.3	57.2	68.6	78.2	96.3
	B						

180R

Reducing Cross

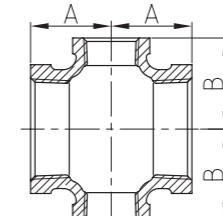

Size	Inch	4X1	4X1 1/4	4X1 1/2	4X2	4X2 1/2	4X3
	mm	100X25	100X32	100X40	100X50	100X65	100X80
Dim. (mm)	A	56	60	62	70	84	82
	B	82	85	85	86	92	90
Size	Inch	3/4X1/2	1X1/2	1X3/4	1 1/4X1/2	1 1/4X3/4	1 1/4X1
	mm	20X15	25X15	25X20	32X15	32X20	32X25
Dim. (mm)	A	30.5	32	34.8	33	36.8	40.1
	B	31.0	35.5	36.8	37.5	41.2	42.4

180R

Reducing Cross

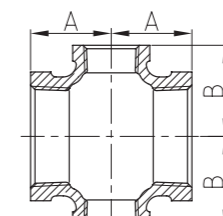

Size	Inch	1 1/2X1/2	1 1/2X3/4	1 1/2X1	1 1/2X1 1/4	2X3/4
	mm	40X15	40X20	40X25	40X32	50X20
Dim. (mm)	A	34.5	38.6	41.9	46.2	40.6
	B	41	44.5	45.7	47.8	50
Size	Inch	2X1	2X1 1/4	2X1 1/2	2 1/2X3/4	2 1/2X1
	mm	50X25	50X32	50X40	65X20	65X25
Dim. (mm)	A	43.9	48.3	51.3	43	47
	B	51.3	53.3	54.9	57	60

180R

Reducing Cross

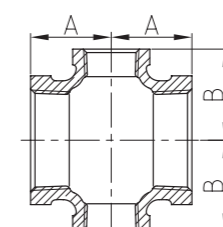

Size	Inch	2 1/2X1 1/4	2 1/2X1 1/2	2 1/2X2	3X3/4	3X1
	mm	65X32	65X40	65X50	80X20	80X25
Dim. (mm)	A	52	55	60.7	45	49
	B	62	63	66.0	65	66
Size	Inch	3X1 1/4	3X1 1/2	3X2	3X2 1/2	
	mm	80X32	80X40	80X50	80X65	
Dim. (mm)	A	53	56.5	64	72	
	B	68	69.5	73.4	76	

220

Coupling

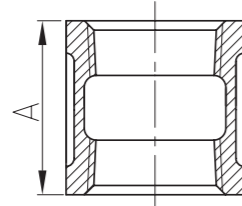

Size	Inch	1/8	1/4	3/8	1/2	3/4	1	1 1/4
	mm	6	8	10	15	20	25	32
Dim. (mm)	A	24.2	26.9	29.5	34.0	38.6	42.4	49
Size	Inch	1 1/2	2	2 1/2	3	4	5	6
	mm	40	50	65	80	100	125	150
Dim. (mm)	A	54.6	64.3	73.2	80.8	93.7	95	105

220S

Left & Right Coupling

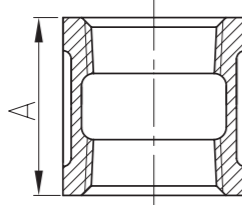

Size	Inch	1/2	3/4	1	1 1/4	1 1/2	2
	mm	15	20	25	32	40	50
Dim. (mm)	A	34.0	38.6	42.4	49	54.6	64.3
Size	Inch						
	mm						
Dim. (mm)	A						

240

Reducing Coupling

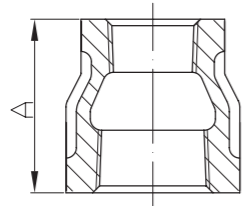

Size	Inch	4X1	4X1 1/4	4X1 1/2	4X2	4X2 1/2
	mm	100X25	100X32	100X40	100X50	100X65
Dim. (mm)	A	111.3	111.3	111.3	111.3	111.3
Size	Inch	4X3	3/8X1/8	3/8X1/4	5X4	6X4
	mm	100X80	10X6	10X8	125X100	150X100
Dim. (mm)	A	111.3	28.7	28.7	122	105

240

Reducing Coupling

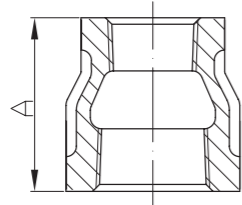

Size	Inch	6X2	6X3	1/2X1/8	1/2X1/4	1/2X3/8	3/4X1/8
	mm	150X50	150X80	15X6	15X8	15X10	20X6
Dim. (mm)	A	105	105	31.8	31.8	31.8	36.6
Size	Inch	3/4X1/4	3/4X3/8	3/4X1/2	1X1/4	1X3/8	1X1/2
	mm	20X8	20X10	20X15	25X8	25X10	25X15
Dim. (mm)	A	36.6	36.6	36.6	42.9	42.9	42.9

240

Reducing Coupling

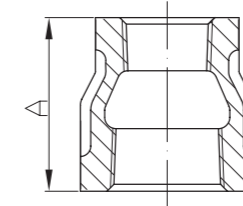

Size	Inch	1X3/4	1 1/4X1/4	1 1/4X3/8	1 1/4X1/2	1 1/4X3/4	1 1/4X1
	mm	25X20	32X8	32X10	32X15	32X20	32X25
Dim. (mm)	A	42.9	52.3	52.3	52.3	52.3	52.3
Size	Inch	1 1/2X1/4	1 1/2X3/8	1 1/2X1/2	1 1/2X3/4	1 1/2X1	2X1/2
	mm	40X8	40X10	40X15	40X20	40X25	50X15
Dim. (mm)	A	58.7	58.7	58.7	58.7	58.7	71.4

240

Reducing Coupling

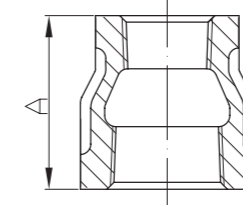

Size	Inch	1 1/2X1 1/4	2X3/4	2X1	2X1 1/4	2X1 1/2
	mm	40X32	50X20	50X25	50X32	50X40
Dim. (mm)	A	58.7	71.4	71.4	71.4	71.4
Size	Inch	2 1/2X1/2	2 1/2X3/4	2 1/2X1	2 1/2X1 1/4	2 1/2X1 1/2
	mm	65X15	65X20	65X25	65X32	65X40
Dim. (mm)	A	82.6	82.6	82.6	82.6	82.6

240

Reducing Coupling

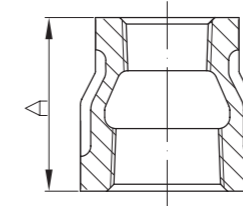

Size	Inch	2 1/2X2	3X1/2	3X3/4	3X1	3X1 1/4
	mm	65X50	80X15	80X20	80X25	80X32
Dim. (mm)	A	82.6	93.7	93.7	93.7	93.7
Size	Inch	3X1 1/2	3X2	3X2 1/2	1/4X1/8	8X6
	mm	80X40	80X50	80X65	8X6	200X150
Dim. (mm)	A	93.7	93.7	93.7	25.4	131

240T

Tapped Reducing Coupling

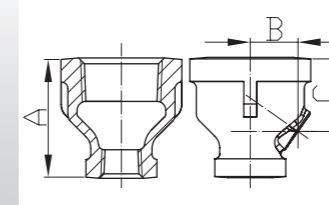

Size	Inch	3/4X1/4X1/8				
	mm	20X8X6				
Dim. (mm)	A	36.5				
	B	14.8				
	C	22.5				
Size	Inch					
	mm					
	mm					
Dim. (mm)	A					
	B					
	C					

241 Outside Hex Bushing

Size	Inch	4X3	3/8X1/8	3/8X1/4	5X4	6X5	1/2X1/8	1/2X1/4
	mm	100X80	10X6	10X8	125X100	150X125	15X6	15X8
Dim. (mm)	A	43.7	16.3	16.3	46	51.6	19	19
Size	Inch	1/2X3/8	3/4X1/8	3/4X1/4	3/4X3/8	3/4X1/2	1X1/2	1X3/4
	mm	15X10	20X6	20X8	20X10	20X15	25X15	25X20
Dim. (mm)	A	19	21.6	21.6	21.6	21.6	25.5	25.5

241 Outside Hex Bushing

Size	Inch	1 1/4X3/4	1 1/4X1	1 1/2X1	1 1/2X1 1/4	2X1 1/4	2X1 1/2
	mm	32X20	32X25	40X25	40X32	50X32	50X40
Dim. (mm)	A	27.4	27.4	29	29	31	31
Size	Inch	2 1/2X2	2 1/2X2	3X2	3X2 1/2	1/4X1/8	8X6
	mm	65X40	65X50	80X50	80X65	8X6	200X150
Dim. (mm)	A	38.4	36.6	40.9	38.9	14.8	70

241N Inside Hex Bushing

Size	Inch	4X3/4	4X1	4X1 1/4	4X1 1/2	4X1 1/2	4X1 1/2
	mm	100X20	100X25	100X32	100X40	100X50	100X65
Dim. (mm)	A	46.2	46.2	46.2	46.2	46.2	46.2
Size	Inch	6X2 1/2	6X2 1/2	6X2 1/2	6X2 1/2	1X1/4	1X1/4
	mm	150X50	150X65	150X80	150X100	25X6	25X8
Dim. (mm)	A	54.7	54.7	54.7	54.7	26.7	26.7

241N Inside Hex Bushing

Size	Inch	1X3/8	1 1/4X3/8	1 1/4X1/2	1 1/2X1/4	1 1/2X3/8
	mm	25X10	32X8	32X10	40X8	40X10
Dim. (mm)	A	26.7	28.9	28.9	30.5	30.5
Size	Inch	1 1/2X1/2	1 1/2X3/4	2X1	2X1	2X1
	mm	40X15	40X20	50X8	50X10	50X15
Dim. (mm)	A	30.5	30.5	32.8	32.8	32.8

241N Inside Hex Bushing

Size	Inch	2X1	2X1	2 1/2X1/2	2 1/2X3/4	2 1/2X1/2	2 1/2X3/4
	mm	50X20	50X25	65X15	65X20	65X25	65X32
Dim. (mm)	A	32.8	32.8	38.4	38.4	38.4	38.4
Size	Inch	3X2	3X2 1/2	3X2	3X2 1/2	3X2	
	mm	80X15	80X20	80X25	80X32	80X40	
Dim. (mm)	A	40.9	40.9	40.9	40.9	40.9	

245 Reducing Hexagon Nipple

Size	Inch	4X2	4X2 1/2	4X3	3/8X1/4	1/2X1/4	1/2X3/8
	mm	100X50	100X65	100X80	10X8	15X8	15X10
Dim. (mm)	A	87	87	87	38	44	44
Size	Inch	3/4X1/4	3/4X3/8	3/4X1/2	1X1/2	1X3/4	1 1/4X1/2
	mm	20X8	20X10	20X15	25X15	25X20	32X15
Dim. (mm)	A	47	47	47	53	53	57

245 Reducing Hexagon Nipple

Size	Inch	1 1/4X3/4	1 1/4X1	1 1/2X1/2	1 1/2X3/4	1 1/2X1
	mm	32X20	32X25	40X15	40X20	40X25
Dim. (mm)	A	57	57	59	59	59
Size	Inch	1 1/2X1 1/4	2X1/2	2X3/4	2X1	2X1 1/4
	mm	40X32	50X15	50X20	50X25	50X32
Dim. (mm)	A	59	68	68	68	68

245 Reducing Hexagon Nipple

Size	Inch	2X1 1/2	2 1/2X1	2 1/2X1 1/4	2 1/2X1 1/2	2 1/2X2
	mm	50X40	65X25	65X32	65X40	65X50
Dim. (mm)	A	68	75	75	75	75
Size	Inch	3X1 1/2	3X2	3X2 1/2	1/4X1/8	
	mm	80X40	80X50	80X65	8X6	
Dim. (mm)	A	83	83	83	31	

280

Hexagon Nipple

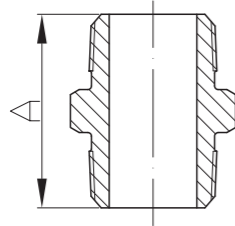

Size	Inch	1/8	1/4	3/8	1/2	3/4	1	1 1/4
	mm	6	8	10	15	20	25	32
Dim. (mm)	A	29	36	38	44	47	53	57
Size	Inch	1 1/2	2	2 1/2	3	4	5	6
	mm	40	50	65	80	100	125	150
Dim. (mm)	A	59	68	75	83	95	103	110

246

Reducing Extension Piece

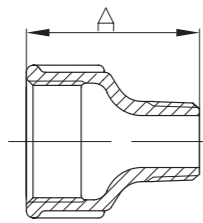

Size	Inch	3/8X1/4	1/2X1/4	1/2X3/8	3/4X3/8
	mm	10X8	15X8	15X10	20X10
Dim. (mm)	A	35	43	43	48
Size	Inch	3/4X1/2	1X1/2	1X3/4	1 1/4X1/2
	mm	20X15	25X15	25X20	32X15
Dim. (mm)	A	48	55	55	60

246

Reducing Extension Piece

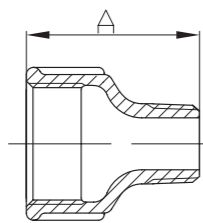

Size	Inch	1 1/4X3/4	1 1/4X1	1 1/2X3/4	1 1/2X1
	mm	32X20	32X25	40X20	40X25
Dim. (mm)	A	60	60	63	63
Size	Inch	1 1/2X1 1/4	2X1	2X1 1/4	2X1 1/2
	mm	40X32	50X25	50X32	50X40
Dim. (mm)	A	63	70	70	70

529A

Extension Piece

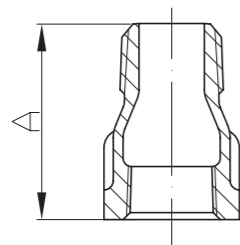

Size	Inch	3/8	1/2	3/4	1	1 1/4	1 1/2
	mm	10	15	20	25	32	40
Dim. (mm)	A	35	43	48	55	60	63
Size	Inch	2	2 1/2	3	4		
	mm	50	65	80	100		
Dim. (mm)	A	70	76	83	97		

291

Cored Plug

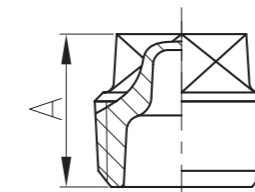

Size	Inch	1/8	1/4	3/8	1/2	3/4	1	1 1/4
	mm	6	8	10	15	20	25	32
Dim. (mm)	A	15.5	18.3	20.1	23.9	27.2	31.8	34.5
Size	Inch	1 1/2	2	2 1/2	3	4	6	
	mm	40	50	65	80	100	150	
Dim. (mm)	A	36.9	39.7	46	49	64.5	71.5	

291S

Solid Plug

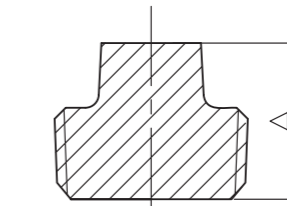

Size	Inch	1/8	1/4	3/8	1/2	3/4	1
	mm	6	8	10	15	20	25
Dim. (mm)	A	15.5	18.3	20.1	23.9	27.2	31.8
Size	Inch	1 1/4	1 1/2	2	2 1/2	3	4
	mm	32	40	50	65	80	100
Dim. (mm)	A	34.5	36.9	39.7	46	49	64.5

291N

Countersunk Plug

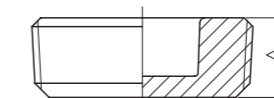

Size	Inch	1/2	3/4	1	1 1/4	1 1/2	2
	mm	15	20	25	32	40	50
Dim. (mm)	A	14.2	16	19.1	20.3	21.1	22.4
Size	Inch	2 1/2	3	4			
	mm	65	80	100			
Dim. (mm)	A	27.2	28.7	31.0			

291-4

Bar Head Plug

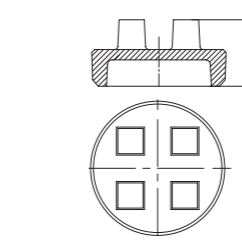

Size	Inch	4	5	6			
	mm	100	125	150			
Dim. (mm)	A	56.4	58.7	67.4			
Size	Inch						
	mm						
Dim. (mm)	A						

300

Cap

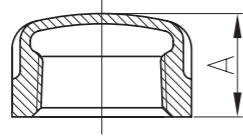

Size	Inch	1/8	1/4	3/8	1/2	3/4	1	1 1/4	1 1/2
	mm	6	8	10	15	20	25	32	40
Dim. (mm)	A Min	13.5	16.0	18.8	22.1	24.6	29.5	32.5	33.8
Size	Inch	2	2 1/2	3	4	5	6	8	
	mm	50	65	80	100	125	150	200	
Dim. (mm)	A	36.8	43.2	45.7	52.8	58.9	64.8	76.2	

310

Locknut

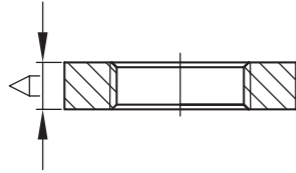
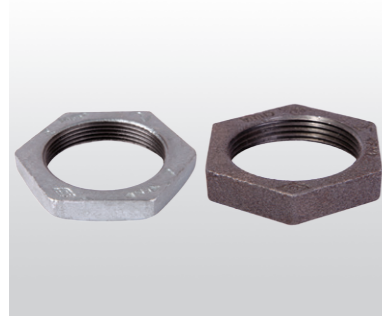

Size	Inch	1/8	1/4	3/8	1/2	3/4	1
	mm	6	8	10	15	20	25
Dim. (mm)	A Min	4.8	6.4	7.1	7.9	8.6	9.7
Size	Inch	1 1/4	1 1/2	2	2 1/2	3	4
	mm	32	40	50	65	80	100
Dim. (mm)	A Min	10.7	11.9	13.5	15	17	20.3

320

Wastenut

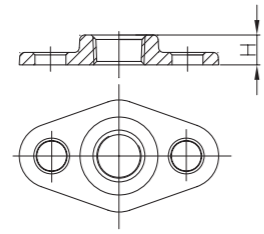
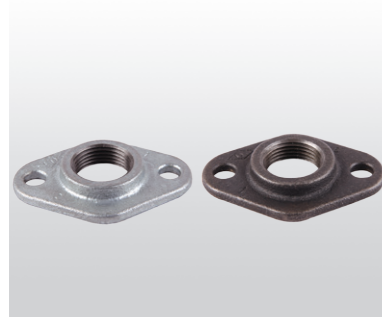

Size	Inch	1/2	3/4	1	1 1/4	1 1/2	2
	mm	15	20	25	32	40	50
Dim. (mm)	A Min	12	13	13.5	15	16	18
Size	Inch	2 1/2					
	mm	65					
Dim. (mm)	A Min	20					

321

Floor Flange

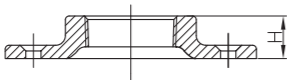
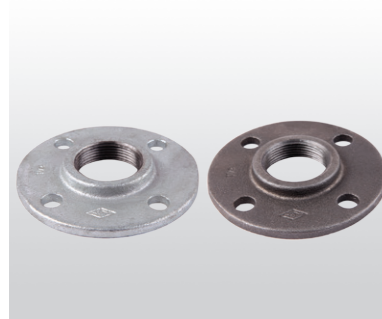

Size	Inch	1/4	3/8	1/2	3/4	1	1 1/4
	mm	8	10	15	20	25	32
Dim. (mm)	A Min	12	14	14	16	17	19
Size	Inch	1 1/2	2	2 1/2	3	4	
	mm	40	50	65	80	100	
Dim. (mm)	A Min	22	25	26.2	27.3	30.5	

321W

Floor Flange without Bolt Hole

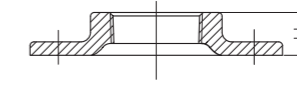
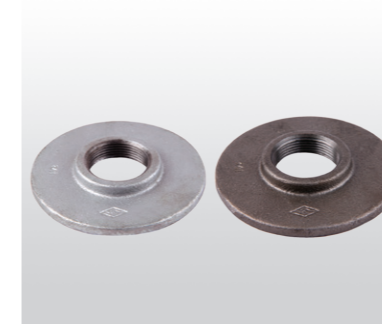

Size	Inch	1/2	3/4	1	1 1/4	1 1/2	2
	mm	15	20	25	32	40	50
Dim. (mm)	A Min	14	16	17	19	22	25
Size	Inch						
	mm						
Dim. (mm)	A Min						

342

Union with Brass Seat

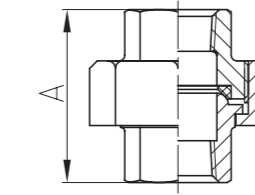
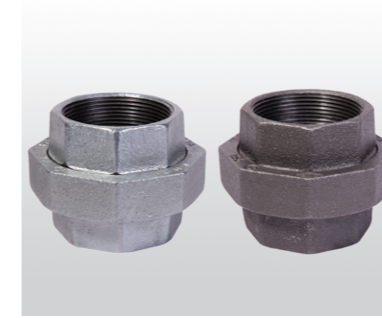

Size	Inch	1/8	1/4	3/8	1/2	3/4	1	1 1/4
	mm	6	8	10	15	20	25	32
Dim. (mm)	A Min	32	36.5	41	43.5	49.5	52.5	57.5
Size	Inch	1 1/2	2	2 1/2	3	4	6	
	mm	40	50	65	80	100	150	
Dim. (mm)	A Min	61	70	82	89	98	145	

1221

Side Outlet Elbow

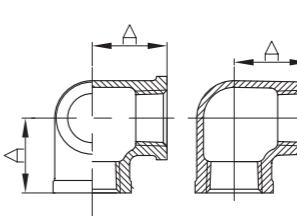

Size	Inch	1/2	3/4	1	1 1/2	2	
	mm	15	20	25	40	50	
Dim. (mm)	A	28	33	38	50	58	
Size	Inch						
	mm						
Dim. (mm)	A						

1223

Side Outlet Tee

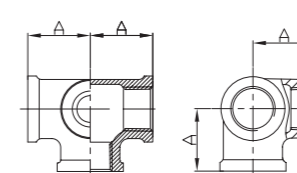

Size	Inch	1/2	3/4	1	1 1/4		
	mm	15	20	25	32		
Dim. (mm)	A	28	33	38	45		
Size	Inch						
	mm						
Dim. (mm)	A						

1224

Side Outlet Cross

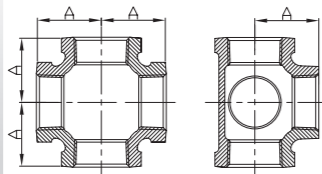

Size	Inch	1	1 1/4	1 1/2			
	mm	25	32	40			
Dim. (mm)	A	38	45	50			
Size	Inch						
	mm						
Dim. (mm)	A						

LCC

Long Compression Coupling

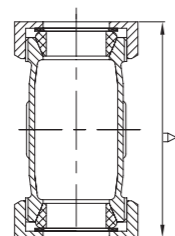

Size	Inch	1/2	3/4	1	1 1/4	1 1/2	2
	mm	15	20	25	32	40	50
Dim. (mm)	A	93	101	109	114	118	121
Size	Inch	2 1/2	3	4			
	mm	65	80	100			
Dim. (mm)	A	137	145	155			

WJFL

Tee Flange

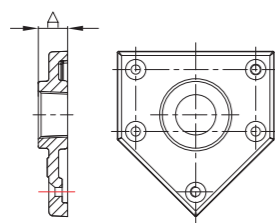

Size	Inch	1					
	mm	25					
Dim. (mm)	A	18					
Size	Inch						
	mm						
Dim. (mm)	A						

Malleable Iron Pipe Fittings

American Standard Class 300

Material: ASTM A197/A197M
 Dimensions: ASME B16.3, B16.14
 Union Dimensions: B16.39
 Threads: ASME B1.20.1
 Size Available: 1/4" - 4"

90 90° Elbow	90R 90° Reducing Elbow	92 90° Street Elbow	120 45° Elbow	121 45° Street Elbow	130 Tee
130R Reducing Tee	220 Coupling	240 Reducing Coupling	300 Cap	342 Union with Brass Seat	

90

90° Elbow

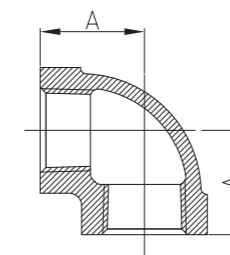
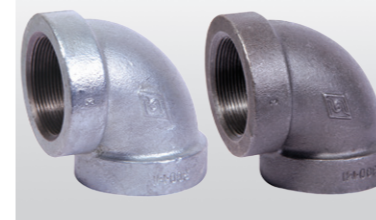

Size	Inch	1/4	3/8	1/2	3/4	1	1 1/4
	mm	8	10	15	20	25	32
Dim. (mm)	A	23.9	26.9	31.8	35.6	41.4	49.3
Size	Inch	1 1/2	2	2 1/2	3	4	
	mm	40	50	65	80	100	
Dim. (mm)	A	54.1	63.5	74.7	85.9	114	

90R

90° Reducing Elbow

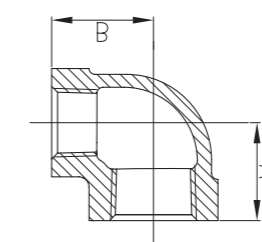

Size	Inch	1/2X3/8	1X3/4	1 1/4X1/2			
	mm	15X10	25X20	32X15			
Dim. (mm)	A	30.2	38.1	36.5			
	B	30.2	39.6	42			
Size	Inch						
	mm						
Dim. (mm)	A						
	B						

92

90° Street Elbow

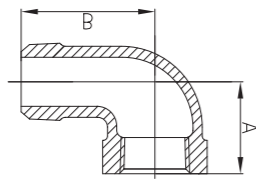

Size	Inch	1/4	3/8	1/2	3/4	1	1 1/4
	mm	8	10	15	20	25	32
Dim. (mm)	A	23.9	26.9	31.8	36.6	41.4	49.3
	B	36.6	41.4	50.8	55.6	65.0	73.2
Size	Inch	1 1/2	2	2 1/2	3		
	mm	40	50	65	80		
Dim. (mm)	A	54.1	63.5	74.7	85.9		
	B	79.5	93.7	114.3	130.3		

120

45° Elbow

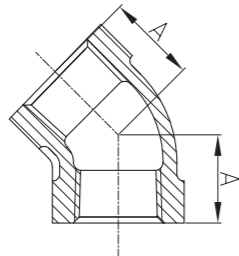

Size	Inch	1/4	3/8	1/2	3/4	1	1 1/4
	mm	8	10	15	20	25	32
Dim. (mm)	A	20.6	22.4	25.4	28.7	33.3	38.1
	B						
Size	Inch	1 1/2	2	2 1/2	3	4	8
	mm	40	50	65	80	100	200
Dim. (mm)	A	42.9	50.8	57.2	63.5	71	106.7
	B						

121

45° Street Elbow

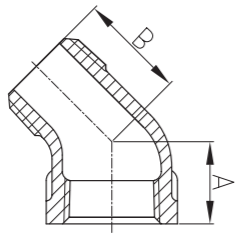

Size	Inch	3/4	1	1 1/4	1 1/2		
	mm	20	25	32	40		
Dim. (mm)	A	28.7	33.3	38.1	42.9		
	B	39.6	46.0	54.1	58.7		
Size	Inch						
	mm						
Dim. (mm)	A						
	B						

130

Tee

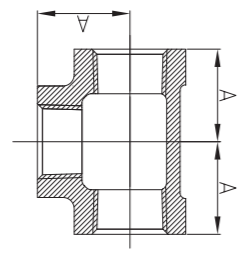

Size	Inch	1/4	3/8	1/2	3/4	1	1 1/4
	mm	8	10	15	20	25	32
Dim. (mm)	A	23.9	26.9	31.8	35.6	41.4	49.3
	B						
Size	Inch	1 1/2	2	2 1/2	3	4	8
	mm	40	50	65	80	100	200
Dim. (mm)	A	54.1	63.5	74.7	85.9	114	162
	B						

130R

Reducing Tee

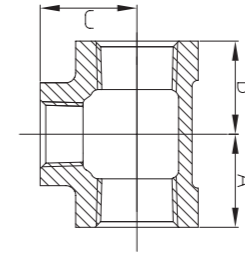

Size	Inch	1/2X3/8	3/4X1/2	1X1/2	1X3/4	1 1/4X1/2
	mm	15X10	20X15	25X15	25X20	32X15
Dim. (mm)	A	30.2	33.3	36.6	38.1	38.1
	B	30.2	33.3	36.6	38.1	38.1
	C	30.2	35.1	38.1	39.6	42.9
Size	Inch	1 1/4X3/4	1 1/4X1	1 1/2X1/2	1 1/2X3/4	1 1/2X1
	mm	32X20	32X25	40X15	40X20	40X25
Dim. (mm)	A	41.4	44.5	41.4	42.9	46.0
	B	41.4	44.5	41.4	42.9	46.0
	C	44.5	46.0	46.0	47.6	50.8

130R

Reducing Tee

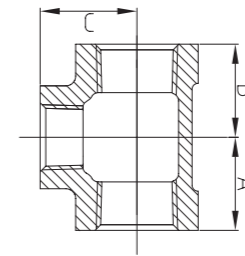

Size	Inch	1 1/2X1 1/4	2X1/2	2X3/4	2X1	2X1 1/4
	mm	40X32	50X15	50X20	50X25	50X32
Dim. (mm)	A	50.8	44.5	46.0	50.8	54.1
	B	50.8	44.5	46.0	50.8	54.1
	C	52.3	52.3	54.1	57.2	58.7
Size	Inch	2X1 1/2	2 1/2X2	3X2	4X2 1/2	4X3
	mm	50X40	65X50	80X50	100X65	100X80
Dim. (mm)	A	57.2	68.3	71.4	94	101.5
	B	57.2	68.3	71.4	94	101.5
	C	60.5	70.0	79.5	101.5	108

220

Coupling

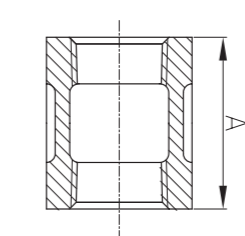

Size	Inch	1/4	3/8	1/2	3/4	1	1 1/4
	mm	8	10	15	20	25	32
Dim. (mm)	A	35.1	41.4	47.8	54.1	60.5	73.2
	B						
Size	Inch	1 1/2	2	2 1/2	3	4	
	mm	40	50	65	80	100	
Dim. (mm)	A	73.2	92.2	104.9	104.9	117	
	B						

240

Reducing Coupling

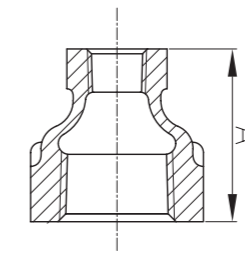

Size	Inch	3/8X1/4	1/2X1/4	1/2X3/8	3/4X1/4	3/4X3/8	3/4X1/2	1X3/8
	mm	10X8	15X8	15X10	20X8	20X10	20X15	25X10
Dim. (mm)	A	36.6	42.9	42.9	44.5	44.5	44.5	50.8
	B							
Size	Inch	1X1/2	1X3/4	1 1/4X1/2	1 1/4X3/4	1 1/4X1	1 1/2X1/2	1 1/2X3/4
	mm	25X15	25X20	32X15	32X20	32X25	40X15	40X20
Dim. (mm)	A	50.8	50.8	60.5	60.5	60.5	68.3	68.3
	B							

240

Reducing Coupling

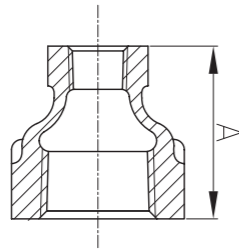

Size	Inch	1 1/2X1	1 1/2X1 1/4	2X1/2	2X3/4	2X1	2X1 1/4	2X1 1/2
	mm	40X25	40X32	50X15	50X20	50X25	50X32	50X40
Dim. (mm)	A	68.3	68.3	81.0	81.0	81.0	81.0	81.0
Size	Inch	2 1/2X1 1/2	2 1/2X2	3X2	3X2 1/2	4X3	8X6	
	mm	65X40	65X50	80X50	80X65	100X80	200X150	
Dim. (mm)	A	93.7	93.7	103.1	103.1	110	131	

300

Cap

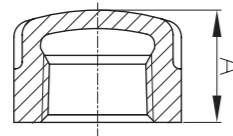

Size	Inch	1/4	3/8	1/2	3/4	1	1 1/4
	mm	8	10	15	20	25	32
Dim. (mm)	A Min	19.8	21.1	24.9	27.4	32.0	35.1
Size	Inch	1 1/2	2	2 1/2	3	4	8
	mm	40	50	65	80	100	200
Dim. (mm)	A Min	36.3	42.7	52.3	55.1	60.5	76.2

342

Union with Brass Seat

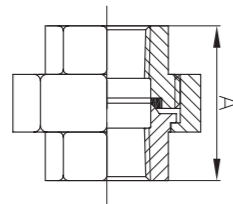
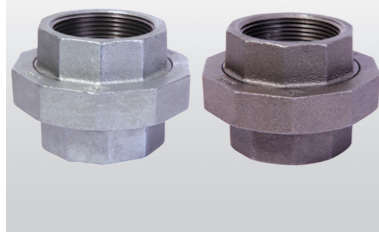

Size	Inch	1/8	1/4	3/8	1/2	3/4	1
	mm	6	8	10	15	20	25
Dim. (mm)	A	32	39.5	43.5	46	54	58.5
Size	Inch	1 1/4	1 1/2	2	2 1/2	3	4
	mm	32	40	50	65	80	100
Dim. (mm)	A	67.5	72.5	82	84.5	104	113.5

Basic Dimension for American Standard Pipe Threads

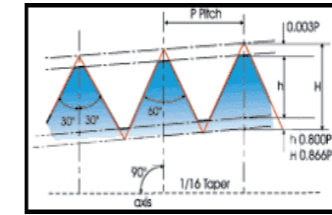

Taper thread
 $H = 0.866025 p$ $p = 0.866025/n$
 $h = 0.800 p = 0.800/n$

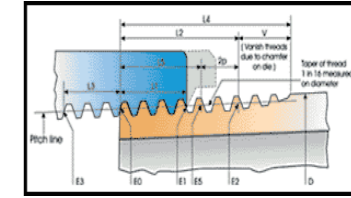

Taper thread
 $L2 = (0.8D + 6.8) l/n = (0.80D + 6.8)p$

Nominal Pipe Size (inches)	O.D. of Pipe (D)	Threads /in (N)	Pitch of Thread (P)	Pitch Dia. at Beginning of External Thread (E0)	Handtight Engagement		Effective Thread, External		Depth of Thread h		
					Length ² (L1)		Diam. ³ (E1)	Length ⁴ (L2)			
					Inch	Thread		Inch		Thread	Diam. ⁵ (E2)
1/8	0.405	27.0	0.03704	0.36351	0.1615	4.36	0.37360	0.2639	7.12	0.38000	0.029
1/4	0.540	18.0	0.05556	0.47739	0.2278	4.10	0.49163	0.4018	7.23	0.50250	0.044
3/8	0.675	18.0	0.05556	0.61201	0.2400	4.32	0.62701	0.4078	7.34	0.63750	0.044
1/2	0.840	14.0	0.07143	0.75843	0.3200	4.48	0.77843	0.5337	7.47	0.79179	0.057
3/4	1.050	14.0	0.07143	0.96768	0.3390	4.75	0.98887	0.5457	7.64	1.00179	0.057
1	1.315	11.5	0.08696	1.21363	0.4000	4.60	1.23863	0.6826	7.85	1.25630	0.069
1 1/4	1.660	11.5	0.08696	1.55713	0.4200	4.83	1.58338	0.7068	8.13	1.60130	0.069
1 1/2	1.900	11.5	0.08696	1.79609	0.4200	4.83	1.82234	0.7235	8.32	1.84130	0.069
2	2.375	11.5	0.08696	2.26902	0.4360	5.01	2.29627	0.7565	8.70	2.31630	0.069
2 1/2	2.875	8.0	0.12500	2.71953	0.6820	5.46	2.76216	1.31375	9.10	2.79062	0.100
3	3.500	8.0	0.12500	3.34062	0.7660	6.13	3.38850	1.2000	9.60	3.41562	0.100
3 1/2	4.000	8.0	0.12500	3.83750	0.8210	6.57	3.88881	1.2500	10.00	3.91562	0.100
4	4.500	8.0	0.12500	4.33438	0.8440	6.75	4.38712	1.3000	10.40	4.41562	0.100
5	5.563	8.0	0.12500	5.39073	0.9370	7.50	5.44929	1.4063	11.25	5.47862	0.100
6	6.625	8.0	0.12500	6.44609	0.9580	7.66	6.50597	1.5125	12.10	6.54062	0.100

Nominal Pipe Size (inches)	Length, L1 Plane to L2 Plane External Thread (L2-L1)		Wrench Makeup Length for Internal Thread ⁷		Diam. ⁸ (E3)	Vanish Thread (V)		Overall ⁸ Length External Thread (L4)	Nominal Complete External Thread ⁵		Height of Thread (h)	Increase in Diam./Thread (0.0625/n)	Basic ⁶ Minor Diam. At Small End of Pipe (K0)
	Inch	Thread	Inch	Thread		Inch	Thread		Length (L5)	Diam. (E5)			
	1/8	0.1024	2.76	0.1111	3	0.35656	0.1285	3.47	0.3924	0.1898	0.37537	0.02963	0.00231
1/4	0.1740	3.13	0.1667	3	0.46697	0.1928	3.47	0.5946	0.2907	0.49556	0.04444	0.00347	0.4329
3/8	0.1678	3.02	0.1667	3	0.60160	0.1928	3.47	0.6006	0.2967	0.63056	0.04444	0.00347	0.5676
1/2	0.2137	2.99	0.2143	3	0.74504	0.2478	3.47	0.7815	0.3909	0.78286	0.05714	0.00446	0.7013
3/4	0.2067	2.89	0.2143	3	0.95429	0.2478	3.47	0.7935	0.4029	0.99286	0.05714	0.00446	0.9105
1	0.2828	3.25	0.2609	3	1.19733	0.3017	3.47	0.9845	0.5089	1.24543	0.06957	0.00543	1.1441
1 1/4	0.2868	3.30	0.2609	3	1.54083	0.3017	3.47	1.0085	0.5329	1.59043	0.06957	0.00543	1.4876
1 1/2	0.3035	3.49	0.2609	3	1.77978	0.3017	3.47	1.0252	0.5496	1.83043	0.06957	0.00543	1.7265
2	0.3205	3.69	0.2609	3	2.25272	0.3017	3.47	1.0582	0.5826	2.30543	0.06957	0.00543	2.1995
2 1/2	0.4555	3.64	0.2500	2	2.70391	0.4337	3.47	1.5712	0.8875	2.77500	0.10000	0.00781	2.6195
3	0.4340	3.47	0.2500	2	3.32500	0.4337	3.47	1.6337	0.9500	3.40000	0.10000	0.00781	3.2406
3 1/2	0.4290	3.43	0.2500	2	3.82188	0.4337	3.47	1.6837	1.0000	3.90000	0.10000	0.00781	3.7375
4	0.4560	3.65	0.2500	2	4.31875	0.4337	3.47	1.7337	1.0500	4.40000	0.10000	0.00781	4.2344
5	0.4693	3.75	0.2500	2	5.37511	0.4337	3.47	1.8400	1.1563	5.46300	0.10000	0.00781	5.2907
6	0.5545	4.44	0.2500	2	6.43047	0.4337	3.47	1.9462	1.2625	6.52500	0.10000	0.00781	6.3461

Note: This information is selected from the International Standard for Pipe Threads, ASME B1.20.1.