

## PRESSURE RELIEF VALVE & PRESSURE SUSTAINING VALVE

## Model 500



The Hyflo Model 500 Pressure Sustaining/Relief Valve is a hydraulically operated, pilot-controlled, modulating valve designed to maintain constant upstream pressure within close limits. This valve can be used for pressure relief, pressure sustaining, back pressure, or unloading functions in a by-pass system.

In operation, the valve is actuated by line pressure through a pilot control system, opening fast to maintain steady line pressure but closing gradually to prevent surges. Operation is completely automatic and pressure settings may be easily changed by adjusting screw on top of the pilot.

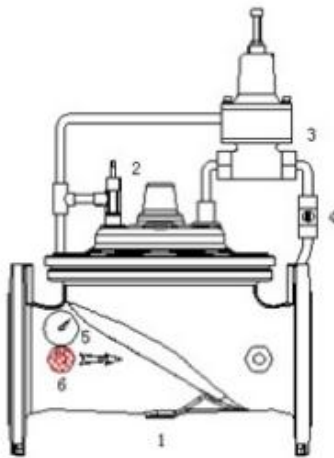

1. Main valve
2. Needle valve
3. Pressure relief Pilot
4. Ball valve
5. Strainer
6. \*Pressure Gauge

- A. Inlet isolation valve
- B. Strainer
- C. Pressure relief valve
- D. Outlet isolation valve

